



SOLAR INVERTERS

ABB string inverters

PRO-33.0-TL-OUTD

33 kW



01

01 PRO-33.0-TL-OUTD
outdoor string inverter

A three-phase inverter from the world's leading power technology company

ABB, a global leader in power and automation technologies, brings decades of experience, technology leadership and application know-how from renewable energies to this new string inverter.

Such experience and technology ensures high quality, safe and reliable solar inverters are delivered every time.

High power package for decentralized PV systems

ABB's three-phase PRO-33 string inverter is designed for medium and large decentralized PV systems either on large-scale commercial and industrial rooftops or ground-mounted PV plants.

The inverter offers cost-efficiency in a high power, wall-mountable package with very high conversion efficiency.

The all-in-one design with built-in and monitored PV plant protection devices reduces the need of costly external devices.

The single maximum power point tracker (MPPT) and optimized MPPT window are suitable for uniform-shaped PV plants with long strings connected to the inverter. The high maximum DC input voltage of up to 1100 V gives PV plant designers extra flexibility and allows more PV modules to be connected in series to reduce cabling costs.

Highlights

- Compact, high power wall-mountable package
- High maximum DC input voltage of up to 1100 V

ABB string inverters cost-efficiently convert the direct current (DC) generated by solar modules into high quality three-phase alternating current (AC) that can be fed into the power distribution network (i.e. grid). Designed to meet the needs of the entire supply chain – from system integrators and installers to end users – these transformerless, three-phase inverters are designed for decentralized photovoltaic (PV) systems installed in commercial and industrial systems up to megawatt (MW) sizes.

- Configurable all-in-one design
- Advanced grid support functions
- Safe and intuitive user interface
- Robust enclosure, with IP65 rating suitable for outdoor installation

Configurable all-in-one design

The ABB PRO-33.0 string inverter comes in three product variants. The standard model with or without DC switch is designed for use with an external string combiner box. The all-in-one model with built-in string combiner box includes a DC switch, string current monitoring with alarm, PV fuses, monitored surge protection devices and tool-less solar quick connectors. The inverter's all-in-one design, with built-in and monitored PV plant protection devices, reduces the need of costly external devices.

High total efficiency maximizes return on investment

The PRO-33.0 inverter offers a high conversion and MPP tracking efficiency in all conditions. A flat efficiency curve provides high revenues in low and high radiation conditions.

Fast and easy commissioning

Fast PV plant commissioning is enabled via pre-programmed country grid code settings that are easily selectable. Extensive certification ensures wide grid code compatibility. Plug and Play DC and AC connectors enable fast and safe cabling. A touch protected installation area provides additional safety and comfort for inverter installation and maintenance.

ABB string inverters

PRO-33.0-TL-OUTD

33 kW



Technical data and types

Type designation	33 kW PRO-33.0-TL-OUTD
Input side	
Absolute maximum DC input voltage ($V_{max,abs}$)	1100 V ⁴⁾
Startup DC input voltage (V_{start})	610 V
Operating DC input voltage range ($V_{dcmin}...V_{dcmax}$)	580 to 950 V
Rated DC input voltage (V_{dcr})	580 V
Rated DC input power (P_{dcr})	33 700 W
Number of independent MPPT	1
MPPT input DC voltage range ($V_{MPPTmin}...V_{MPPTmax}$) at P_{acr}	580 to 850 V
Maximum DC input current (I_{dcmax})/for each MPPT ($I_{MPPTmax}$)	58 A
Maximum input short circuit current for each MPPT	80 A
Number of DC input pairs for each MPPT	1 in Standard and -S version/8 in -SX version
DC connection type	PV quick fit connector ³⁾ on -SX version / Screw terminal block on Standard and -S version
Input protection	
Reverse polarity protection	Yes, from limited current source
Input over voltage protection for each MPPT - varistor (-/S) version	Yes
Input over voltage protection - plug in modular surge arrester (-SX version)	Type 2
Photovoltaic array isolation control	According to local standard
DC switch rating for each MPPT (version with DC switch)	58 A / 1000 V, 50 A / 1200 V
Fuse rating (versions with fuses)	15 A / 1100 V
Output side	
AC grid connection type	Three-phase 3W+PE or 4W+PE
Rated AC power (P_{acr} @ $\cos\phi>0.99$)	33 000 W
Maximum apparent power (S_{max})	33 000 VA
Rated AC grid voltage (V_{acr})	400 V
AC voltage range	320 to 480 V ¹⁾
Maximum AC output current ($I_{ac,max}$)	50.3 A
Contributory fault current	50.3 A
Rated output frequency (f_r)	50 Hz/60 Hz
Output frequency range ($f_{min}...f_{max}$)	47 to 53 Hz/57 to 63 Hz ²⁾
Nominal power factor and adjustable range	> 0.995, with $P_{acr} = 33.0$ kW, adj. ± 0.9 with $P_{acr} = 29.7$ kW, adj. ± 0 to 1 with S = 33.0 kVA
Total current harmonic distortion	< 3%
AC connection type	Fixed plug type connector
Output protection	
Anti-islanding protection	According to local standard
Maximum external AC overcurrent protection	80 A
Output overvoltage protection - varistor	5

ABB PRO-33.0-TL-OUTD string inverter block diagram

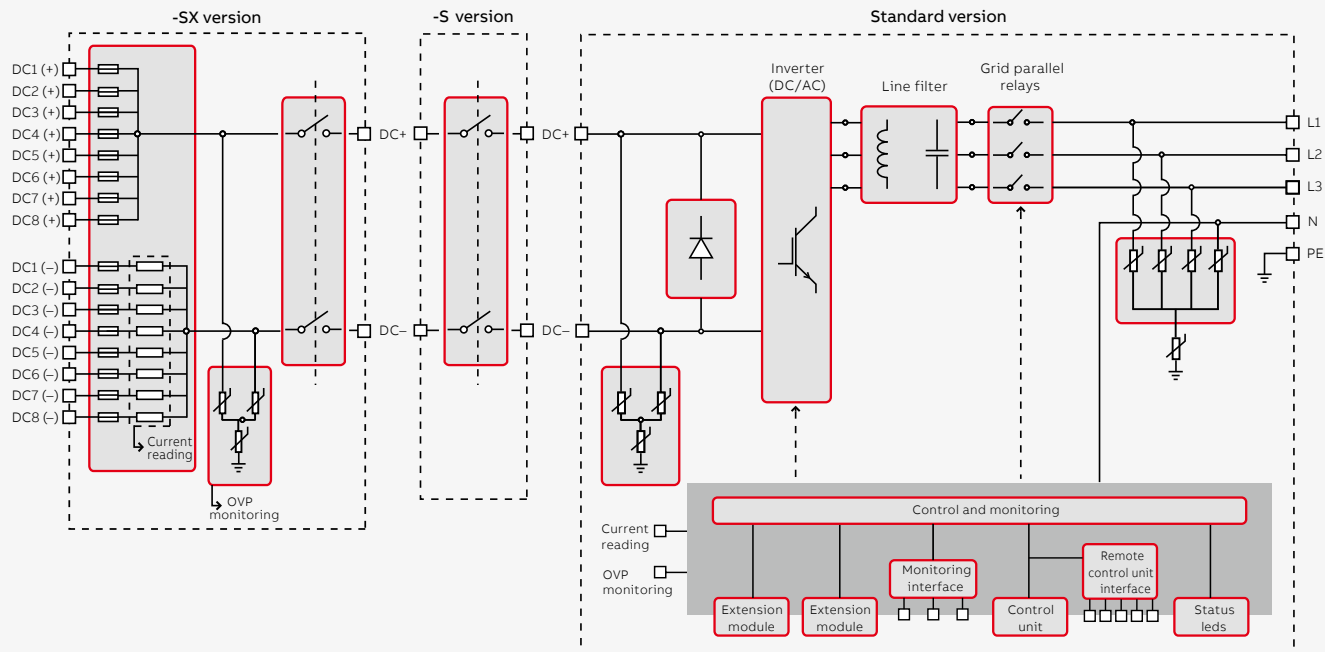

Technical data and types

Type designation	33 kW PRO-33.0-TL-OUTD
Operating performance	
Maximum efficiency (η_{max})	98.3%
Weighted efficiency (EURO/CEC)	98.0% / 98.1%
Feed in power threshold	20 W
Night consumption	< 1 W
Communication	
Remote monitoring	VSN700 Data Logger (opt.)
User interface	Detachable graphical display
Environmental	
Ambient temperature range	-25 to +60°C / -13 to 140°F with derating above 45°C/113°F
Relative humidity	0 to 100% condensing
Sound pressure level, typical	67 dBA @ 1 m
Maximum operating altitude without derating	3000 m / 9840 ft
Physical	
Environmental protection rating	IP65 (IP54 fans)
Cooling	Forced
Dimension (H x W x D) mm/inch	740 x 520 x 300 mm / 29.1" x 20.5" x 11.8"
Weight kg / lb	< 66.0 kg / 146 lbs (standard version)
Mounting system	Wall bracket
Safety	
Isolation level	Transformerless
Marking	CE, RCM
Safety and EMC standard	IEC/EN 62109-1, IEC/EN 62109-2, EN61000-6-2, AS/NZS 3200, EN61000-6-3, EN61000-3-11, EN61000-3-12
Grid standard (check availability)	CEI 0-21, CEI 0-16, DIN V VDE V 0126-1-1, VDE-AR-N 4105, G59/3, C10/11, EN 50438 (not for all national appendices), PPC Greece, RD 1699, RD 413, RD 661, P.O. 12.3, UNE206007-1, AS 4777, BDEW, NRS-097-2-1, SAGC, MEA, PEA, IEC 61727, IEC 62116, ABNT NBR16149/16150, VFR-2014
Available product variants	
Standard	PRO-33.0-TL-OUTD-400
With DC switch	PRO-33.0-TL-OUTD-S-400
With DC switch, fuses and DC surge arresters	PRO-33.0-TL-OUTD-SX-400

¹⁾ The AC voltage range may vary depending on specific country grid standard

²⁾ The frequency range may vary depending on specific country grid standard

³⁾ Please refer to the document "String inverters – Product manual appendix" available at www.abb.com/solarinverters for information on the quick-fit connector brand and model used in the inverter

⁴⁾ Inverter does not start >1000 V

Remark. Features not specifically listed in the present data sheet are not included in the product



Efficiency curves of PRO-33.0-TL-OUTD

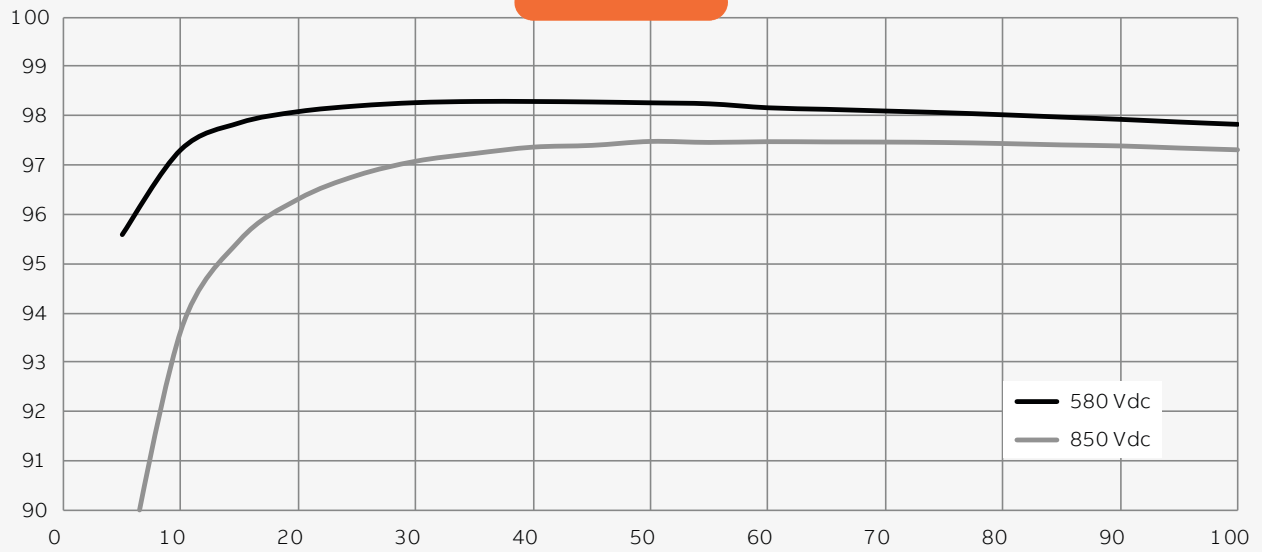

For more information please contact your local ABB representative or visit:

www.abb.com/solarinverters
www.abb.com

We reserve the right to make technical changes or modify the contents of this document without prior notice. With regard to purchase orders, the agreed particulars shall prevail. ABB AG does not accept any responsibility whatsoever for potential errors or possible lack of information in this document.

We reserve all rights in this document and in the subject matter and illustrations contained therein. Any reproduction, disclosure to third parties or utilization of its contents – in whole or in parts – is forbidden without prior written consent of ABB AG. Copyright © 2017 ABB. All rights reserved.

